

Safety, Operational and Maintenance Instructions with Telescopic Soft Close, Stabilisers and Lightening Latches

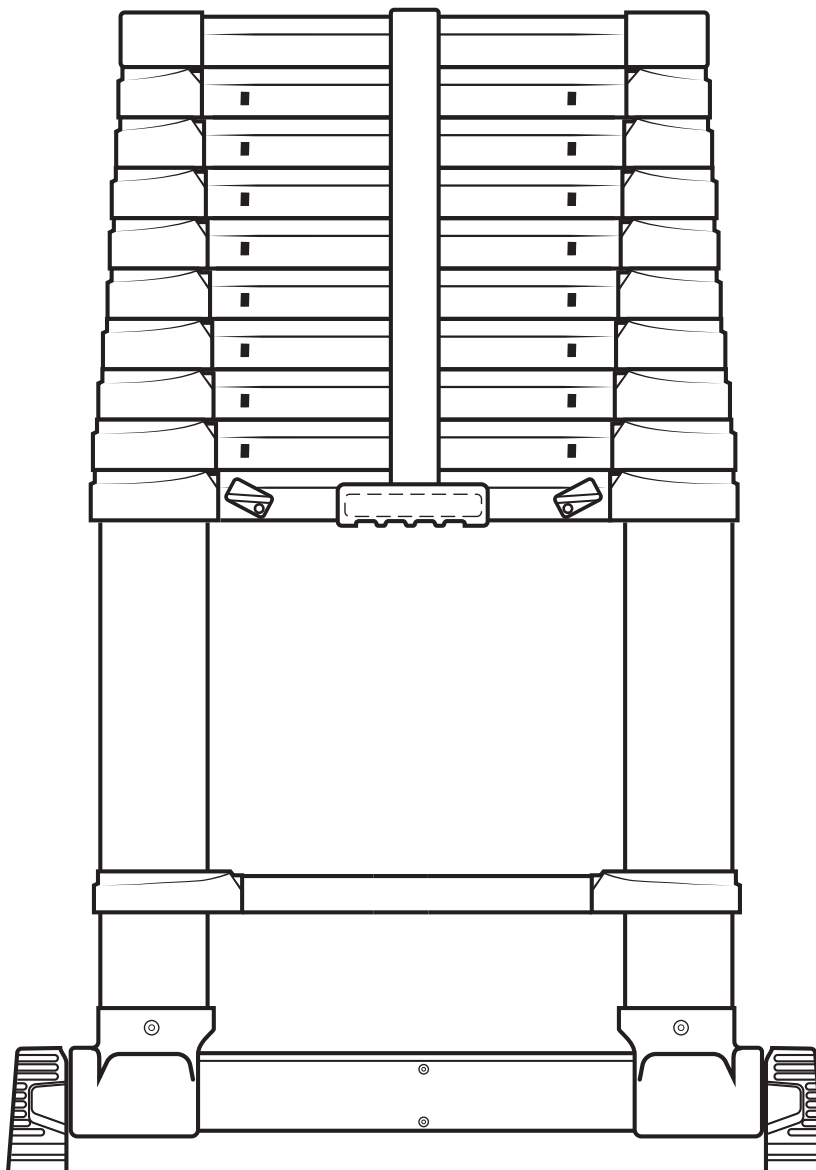

Ladder may differ from actual product



IMPORTANT: Refer to instruction manual.
All instructions must be read carefully before using your
XTEND+CLIMB.® Save these instructions for future reference.

Production Date: 02:26 | REV2026

CONTENTS

Component Identification.....	3
Safety Symbols.....	4
List of Items to be Inspected.....	6
Operation and safety Instructions	
Extending the Ladder (Partially).....	7
Extending the Ladder (Fully).....	8
Closing the Ladder.....	10
Maintenance Tips	
Wet Ladder.....	12
Oxidised Ladder.....	12
Paint or other Substances.....	13
Hard to Move Latches.....	13
Difficulty in Opening or Closing the Ladder.....	14
Winter Conditions.....	14
Ladder Inspection.....	15
Repairs and Maintenance.....	15
Keep all Documents.....	15
Warranty.....	15
Specifications.....	16

COMPONENT IDENTIFICATION

A. Top Section - Upper horizontal section of the ladder.

B. Top Cap - Top section of the ladder that encloses the upper stile.

C. Lock Indicator - Green/Black indicator that alerts the user when the section is locked or unlocked (*Only climb this side of ladder climbing side has release latches and lock indicator window with a sticker on the rung*).

D. Rung - Horizontal section used for climbing the ladder.

E. Stile - Vertical member used to support the rungs and the ladder structure.

F. Coupling - The section that connects the rung to the stile of the ladder.

G. Grip Handle - Ergonomic pad on the bottom of the second rung from the bottom that the user uses to comfortably transport the ladder.

H. Lightning Release Latch - Mechanical button or switch that allows the user to unlock the section at the bottom to start the closing process.

I. Securing Strap - Nylon strap with hook and loop fasteners, which holds the ladder together during transportation and storage.

J. Bottom Rung - Lower horizontal section used for climbing the ladder.

K. Stabiliser/Bottom Foot - Ladder base with anti-slip design that supports the ladder during use.

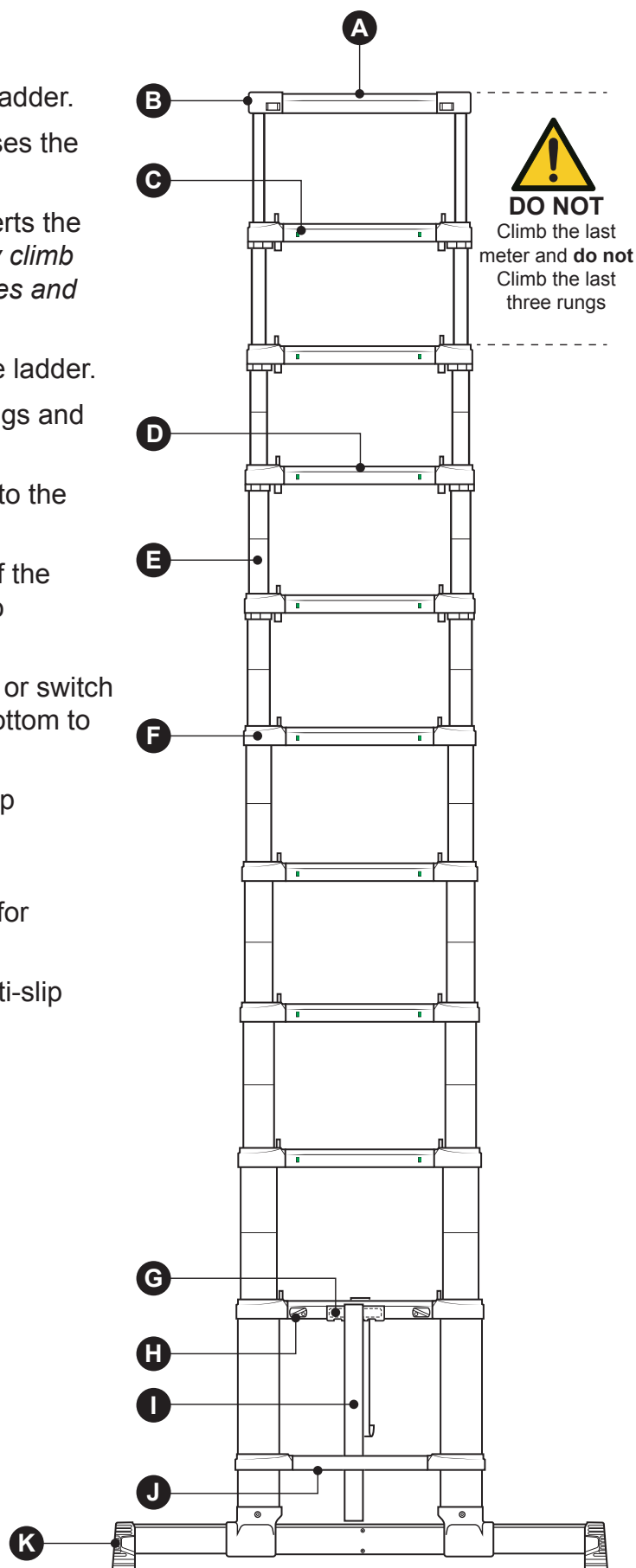

SAFETY SYMBOLS



DANGER: FALLS FROM THE LADDER. FAILURE TO UNDERSTAND AND FOLLOW ALL SAFETY RULES AND OPERATIONAL INSTRUCTIONS COULD RESULT IN SERIOUS INJURY OR DEATH.

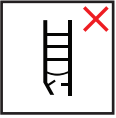

Inspect the ladder after delivery. Before every use visually check the ladder is not damaged and is safe to use. Do not use a damaged ladder.



Do not use the ladder if you are not fit enough. Certain medical conditions or medication, alcohol or drug abuse could make ladder use unsafe.



Do not use the ladder on a unlevel or uneven base

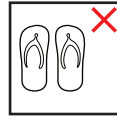

Do not wear unsuitable footwear when climbing a ladder.



Do not overreach.

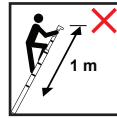

Do not climb on the last meter (three rungs) of the telescopic ladder.



Do not erect ladder on contaminated ground.



Do not place your hands/fingers in the rung area (area of shearing) when bringing the ladder in to its possible positions of use.



Do not ascend or descend unless you are facing the ladder.

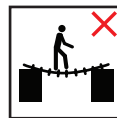

Do not use the ladder as a bridge.



Do not carry equipment which is heavy or difficult to handle while using a ladder.

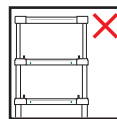

Do not climb on top 3 rungs.



Avoid work that imposes a sideways load on ladders, such as side-on drilling through solid materials.

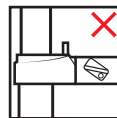

Un-locked lightning latch



Do not lean the ladder against unsuitable surfaces.



Maximum total load.



Maximum number of users.



Keep a secure grip on the ladder when ascending and descending. Maintain a handhold whilst working from a ladder or take additional safety precautions if you cannot.



Ladder for homeowner use or non professional.

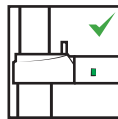

When locked indicator window is green it is safe to climb.



Ladder for professional use.

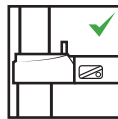

Locked lightning release latch.



Leaning ladders with rungs shall be used at the correct angle.



Only Climb this Side of Ladder - Climbing Side has release latches and Lock Indicator Window with a sticker on rung.

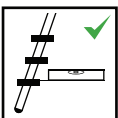

Leaning ladders with steps shall be used that the steps are in a horizontal position.



WARNING: ELECTRICITY HAZARD: Identify any electrical risks in the work area, such as overhead lines or other exposed electrical equipment and do not use the ladder where electrical risks occur.

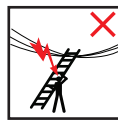

Only use the ladder in the direction as indicated, only if necessary due to design of ladder.



Ladders used for access to a higher level shall be extended at least 1m above the landing point and secured, if necessary.



Locking mechanisms for all extended rungs shall be checked and locked before use.



LIST OF ITEMS TO BE INSPECTED

For regular inspection, the following items shall be taken into account:

- ✓ Check the ladder on purchase and prior to each usage.
- ✓ Check that the stiles/legs (uprights) are not bent, bowed, twisted, dented, cracked, corroded or rotten.
- ✓ Check that the stiles/legs around the fixing points for other components are in good condition.
- ✓ Check that fixings (usually rivets, screws or bolts) are not missing, loose, or corroded.
- ✓ Check that rungs/steps are not missing, loose, excessively worn, corroded or damaged.
- ✓ Check that the hinges between front and rear sections are not damaged, lose or corroded.
- ✓ Check that the locking stays horizontal, back rails and corner braces are not missing, bent, loose, corroded or damaged.
- ✓ Check that the rung hooks are not missing, damaged, lose or corroded and engage properly on the rungs.
- ✓ Check that guide brackets are not missing, damaged, lose or corroded and engage properly on the mating stile.
- ✓ Check that ladder feet/end caps are not missing, loose, excessively worn, corroded or damaged.
- ✓ Check that the entire ladder is free from contaminants (e.g. dirt, mud, paint, oil, grease, wet paint or snow). Do not use ladder if contaminated.
- ✓ Check that locking latches (if fitted) are not damaged or corroded and function correctly.
- ✓ Check that the platform (if fitted) has no missing parts or fixings and is not damaged or corroded.
- ✓ Check that the ladder is suitable for the task. Use a ladder only for the tasks for which it has been designed.
- ✓ Check that the ground supporting the ladder is firm and level.
- ✓ Check your surroundings when erecting the ladder. Take the necessary precautions to ensure your own safety and that of others when erecting and using a ladder at entrances, in passageways, etc.

If any of the above checks cannot be fully satisfied, you **SHOULD NOT** use the ladder.

For special ladder types, further items identified by the manufacturer shall be taken into account.

All checkpoints according to EN131-6: 2019, Annex A shall be mentioned when applicable. Furthermore the following checkpoints shall be added:

- ✓ Check if the locking indicators are working and if they are visible.
- ✓ Check the brackets on cracks and other failures, such as:
 - No rupturing of parts shall be observed.
 - There shall be no relative movement between the brackets and the rungs/steps.
- ✓ Do not use the ladder outside in adverse weather conditions, such as strong wind.
- ✓ For professional use a risk assessment shall be carried out respecting the legislation in the country of use.
- ✓ When positioning the ladder take into account risk of collision with the ladder e.g. from pedestrians, vehicles or doors. Secure doors (not fire exits) and windows where possible in the work area.
- ✓ Use non-conductive ladders for unavoidable live electrical work.
- ✓ Do not modify the ladder design.
- ✓ Do not move a ladder while standing on it.
- ✓ For outdoor use caution to the wind.
- ✓ Ladder shall never be moved from the top.
- ✓ The ladder shall be inspected after delivery and before every use to confirm condition and operation of all parts.
- ✓ Only climb the side of the ladder that has lighting latches, lock indicator windows and stickers.
- ✓ Do not spend long periods on a ladder without regular breaks (tiredness is a risk).
- ✓ The ladder shall be inspected after delivery and before every use to confirm condition and operation of all parts.
- ✓ **WARNING:** Keep at least 2 meters away from non-insulated live electrical equipment.
- ✓ **WARNING:** Steel is electrically conductive.

OPERATIONAL AND SAFETY INSTRUCTIONS

Extending The Ladder (Partially)

fig 1. Place the ladder on a sturdy, level surface suitable on which to use the ladder. Release the strap that secures the ladder in the "storage configuration".

fig 2. Place your foot on the bottom rung (closest to the ground). With both hands, pull up the 3rd rung – counting from the ground.

fig 3. Lift ladder off the ground very slightly – stabilisers will automatically telescope out to the correct extension. Please confirm the stabilisers are firmly locked in place.

fig 4. Place your foot on the bottom rung to hold the ladder in place. With both hands pull up on the rung that you determine will be the highest point to which you would like to extend the ladder.

fig 5. Extend each rung until it is locked in place. You will hear an audible click and see a green indicator on the rung below confirming that section is fully extended and locked. Continue extending the ladder until you have reached your desired height.

fig 6. Once fully extended, each section should show a green lock indicator. Visually inspect the ladder for any damage, debris and ensure that all open sections are locked.

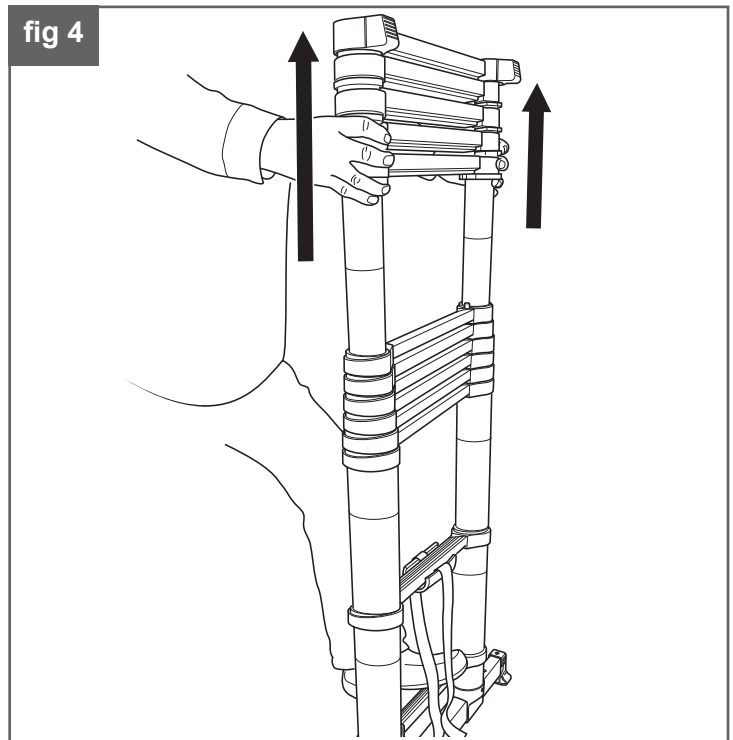
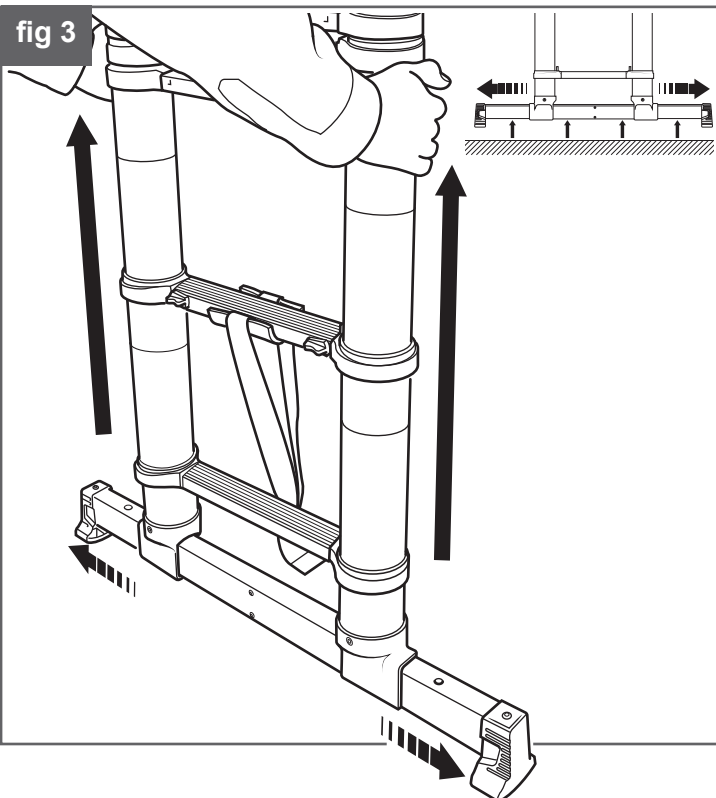
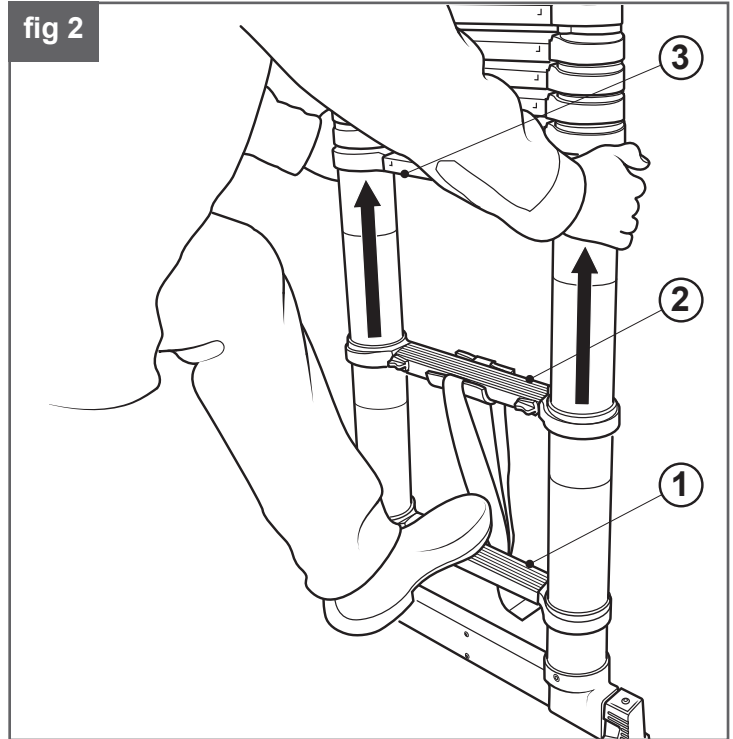
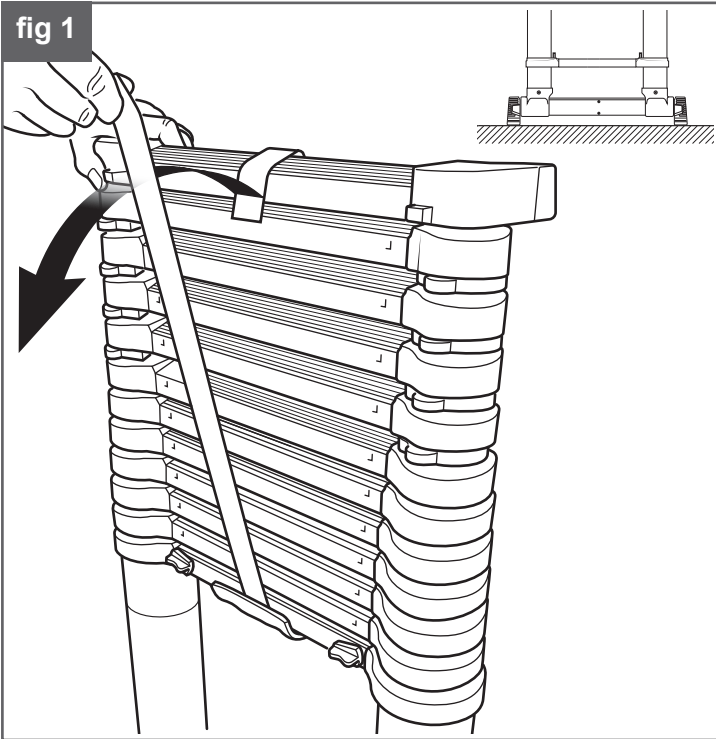

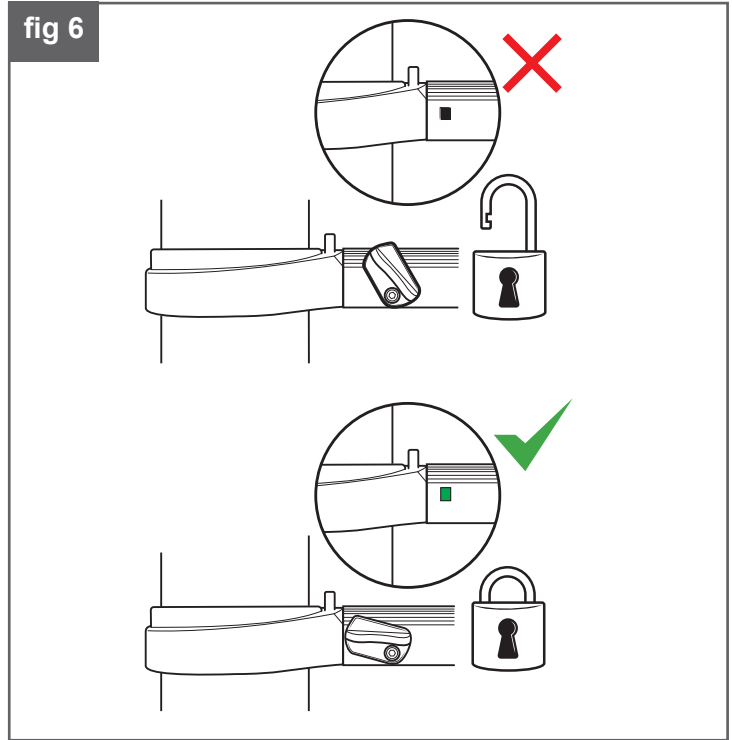
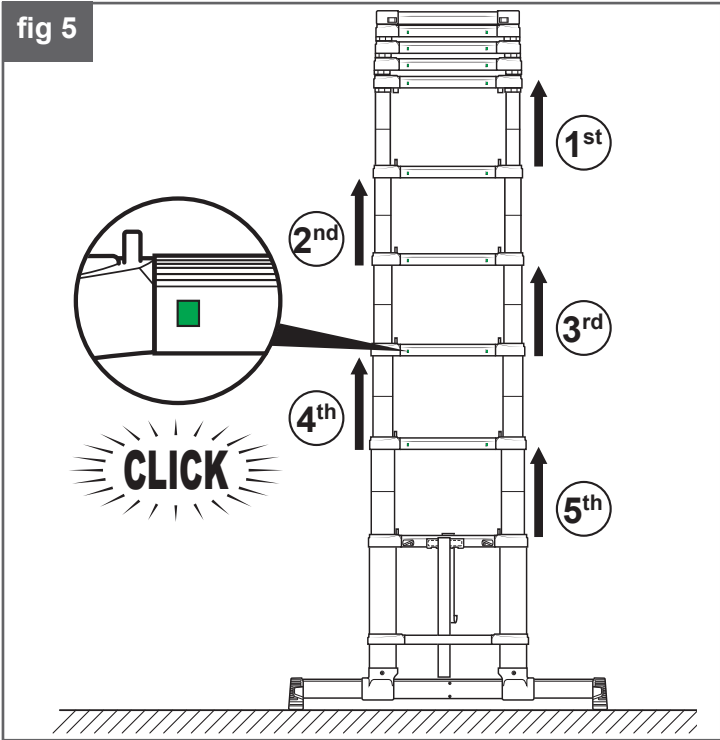

Extending The Ladder (Full Working Height)

- fig 7.** Place the ladder on a sturdy, level surface suitable on which to use the ladder. Release the strap that secures the ladder in the “storage configuration”.
- fig 8.** Place your foot on the bottom rung (closest to the ground). With both hands, pull up the 3rd rung – counting from the ground.
- fig 9.** Lift ladder off the ground very slightly – stabilisers will automatically telescope out to the correct extension. Please confirm the stabilisers are firmly locked in place.
- fig 10.** Place your foot on the bottom rung to hold the ladder in place and extend the first rung.
- fig 11.** Extend each rung until it is locked in place. You will hear an audible click and see a green indicator on the rung below confirming that section is fully extended and locked. Continue extending the ladder all the way up. Once fully extended, each section should show a green lock indicator. Visually inspect the ladder for any damage, debris and ensure that all open sections are locked.

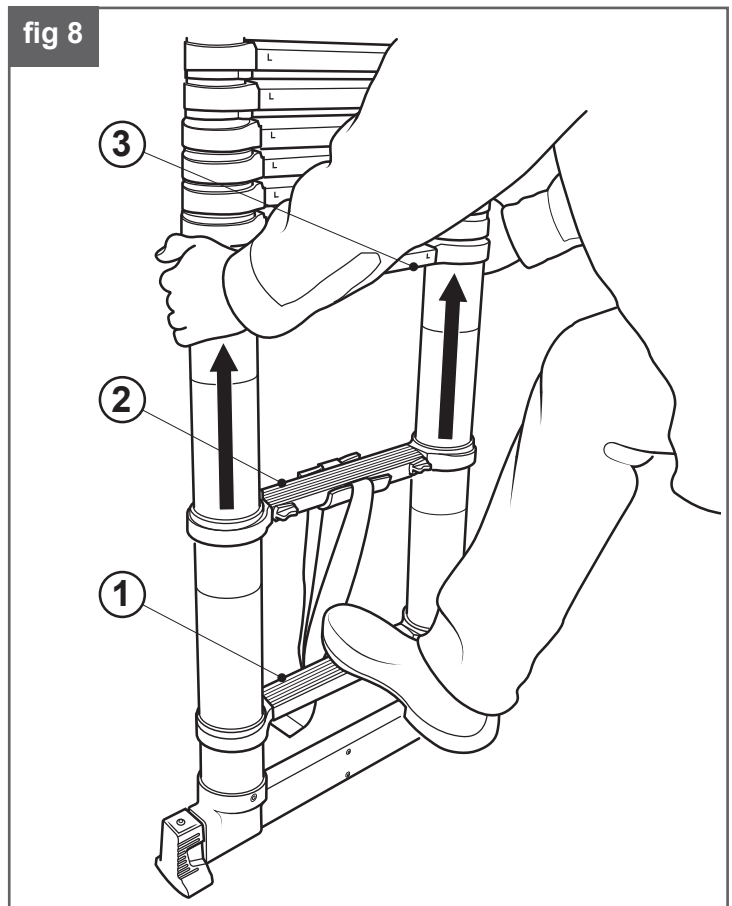
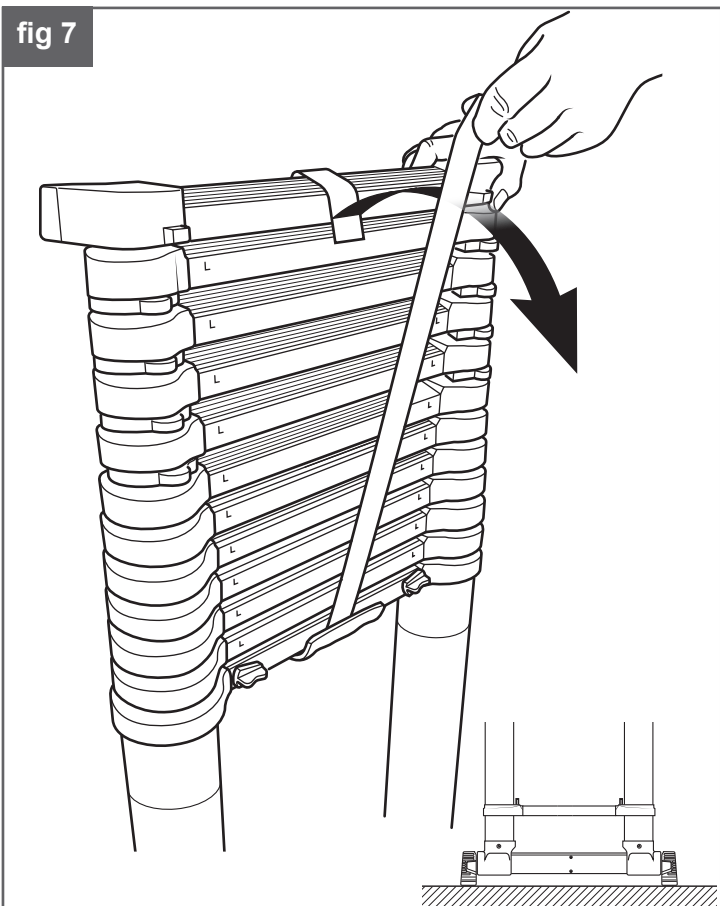



fig 9

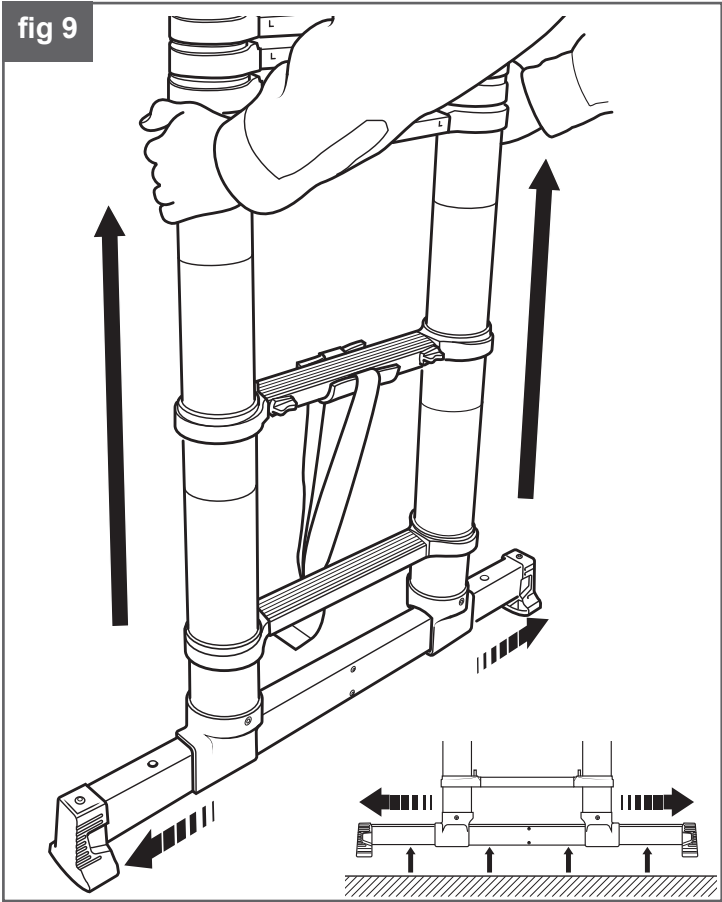

fig 10

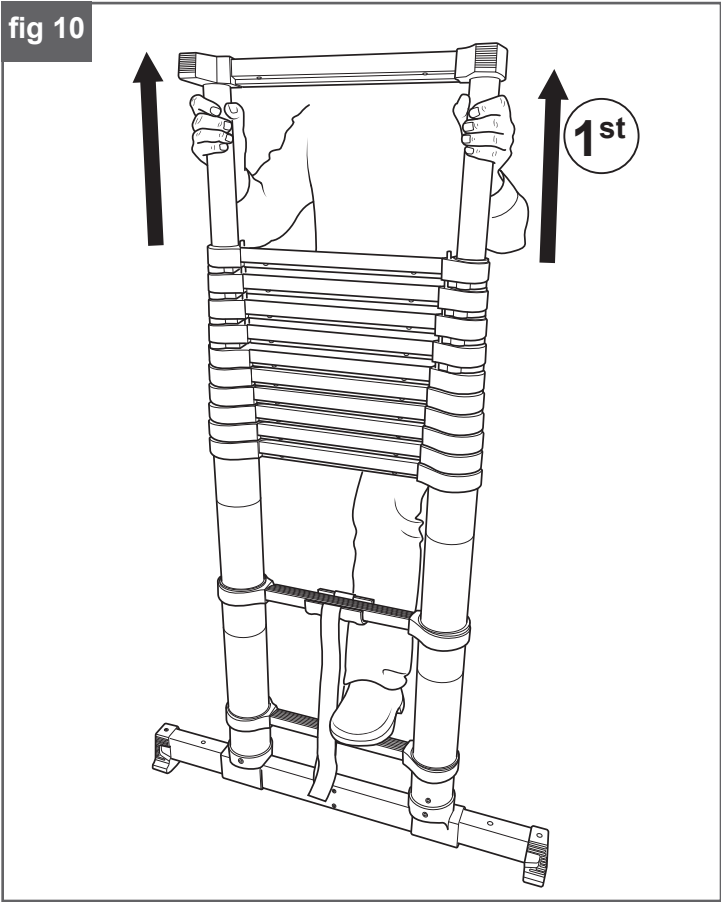
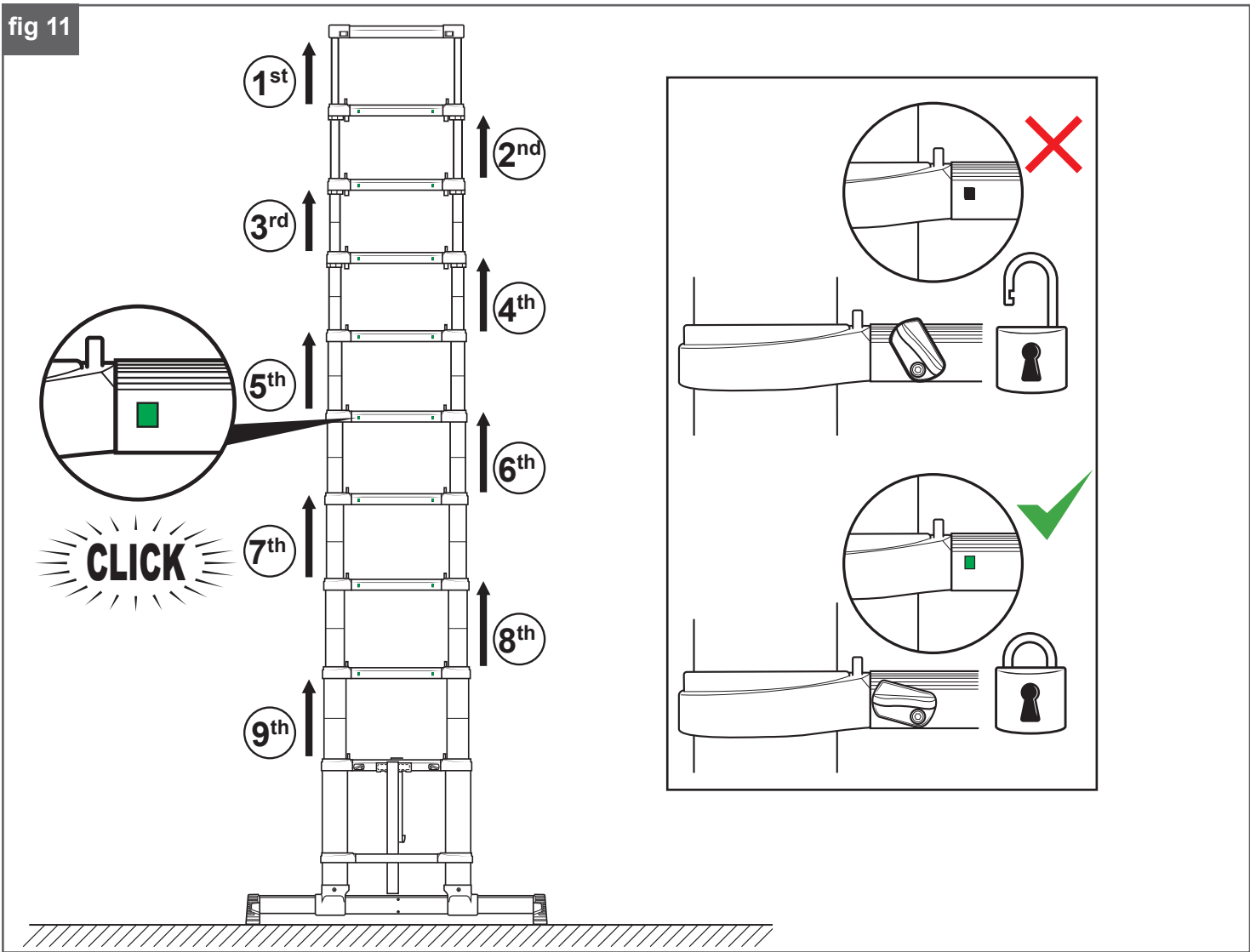

fig 11



Closing The Ladder

fig 12. Great care should be taken when retracting the ladder. Do not place your hands, fingers or thumbs on, or between rungs or couplings above the closing rung.

fig 13. Ensure that you are on a sturdy level surface. Hold the ladder upright. Place thumbs on the release mechanism located on the second to bottom rung from the ground. Push each release mechanism inward one at a time to unlock the ladder while securing the ladder with the other hand.

fig 14. The entire ladder is now completely unlocked (**DO NOT CLIMB THE LADDER AFTER PERFORMING THIS PROCEDURE**). Due to our "soft closing" system, the rungs may need slight guidance while retracting.

figs 15, 16. Starting with the bottom step (1st), pull the rung down until it locks into position, then apply the same action through to the last rung (9th), depending upon ladder model).

fig 17. Push the stabilisers bars inward to retract each side to its "storage configuration".

fig 18. Attach the strap that secures the ladder around the top rung.

fig 12

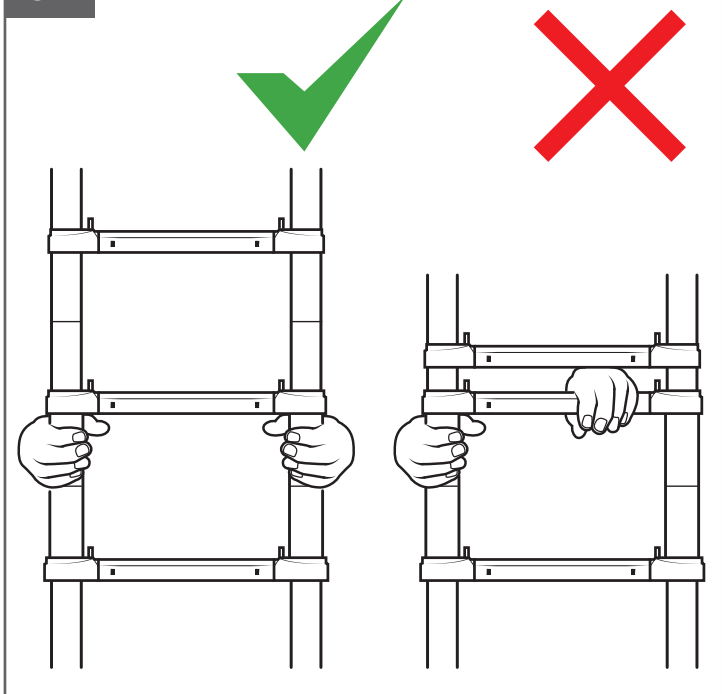

fig 13

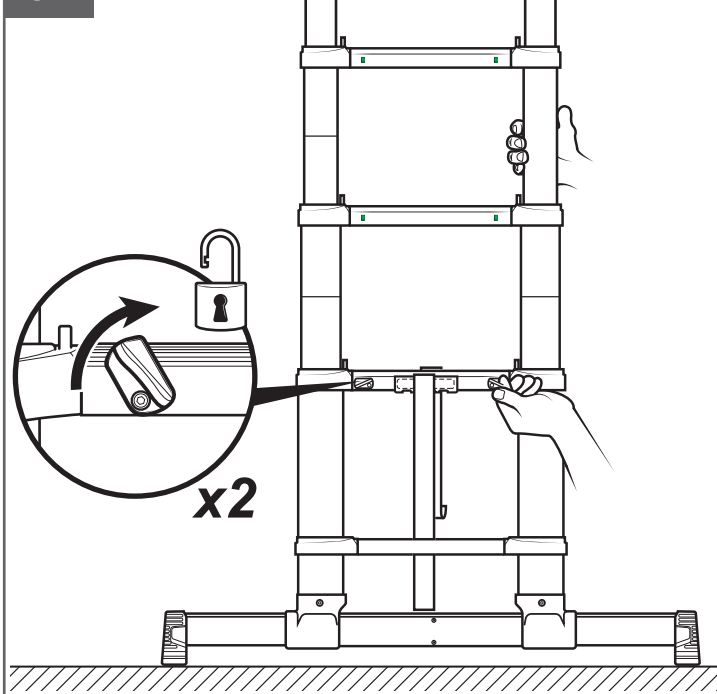

fig 14

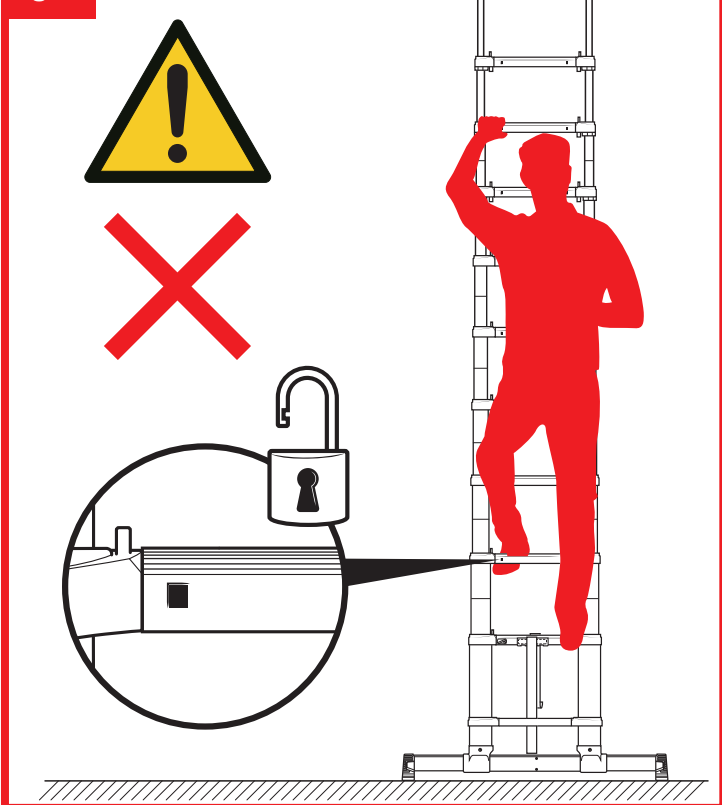

fig 15

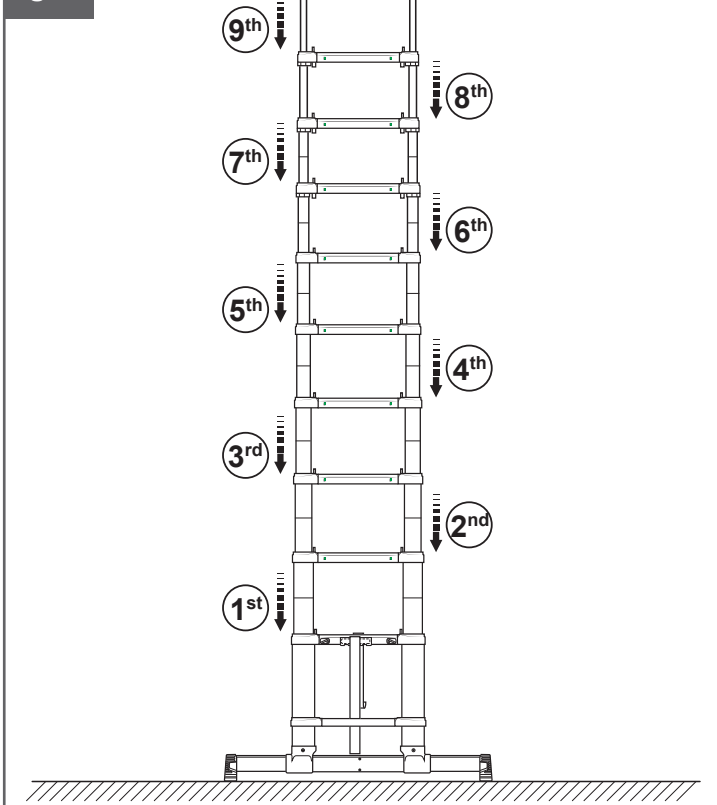



fig 16

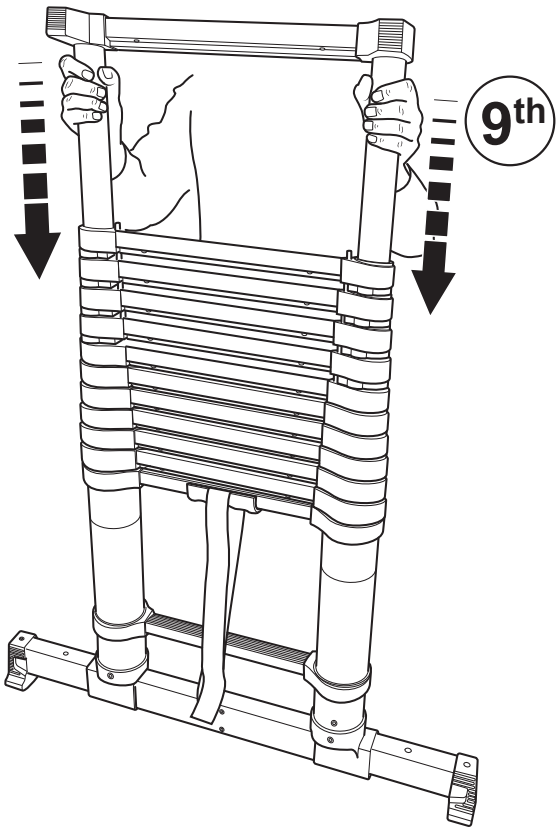

fig 17

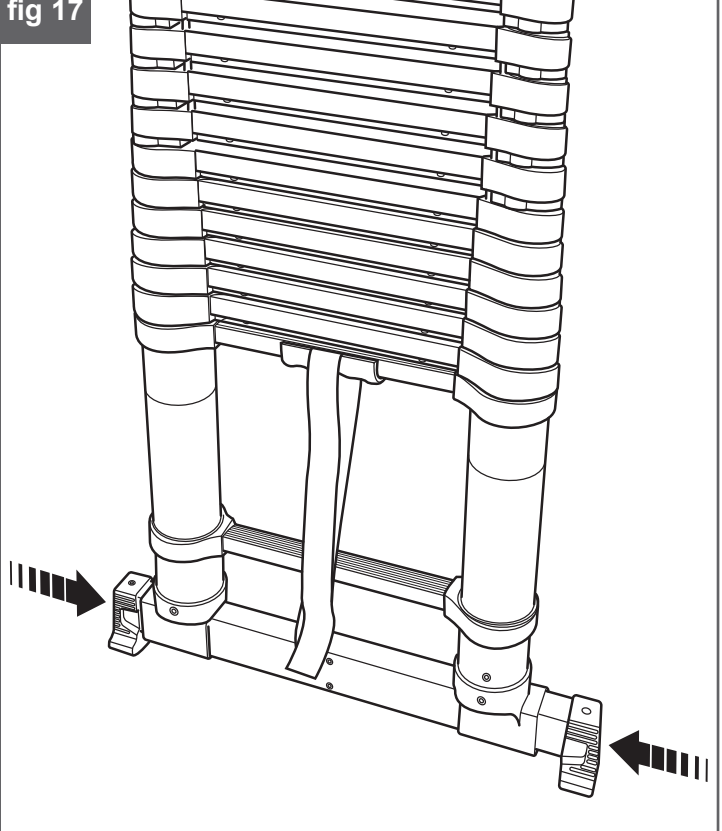
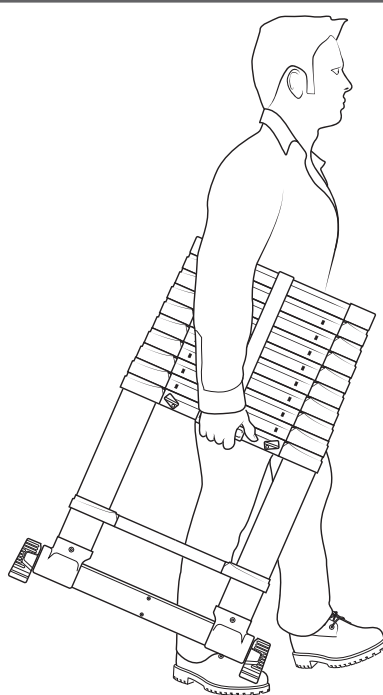
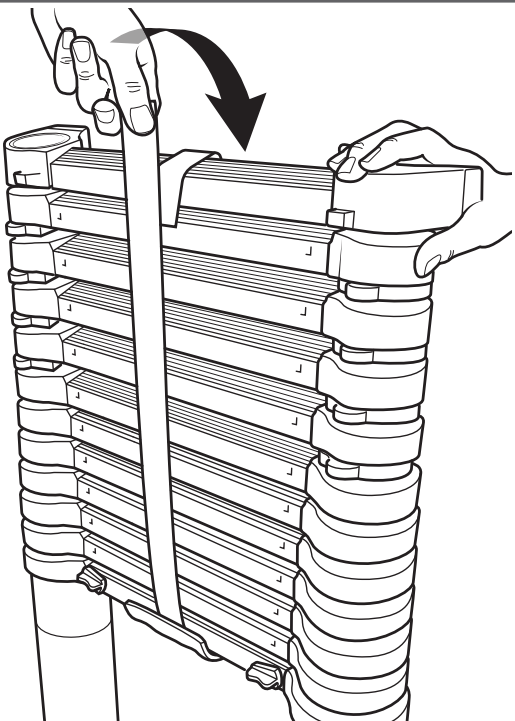
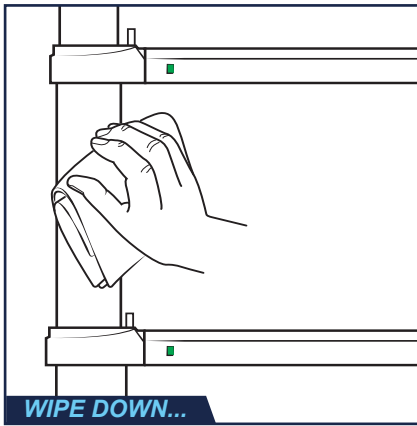
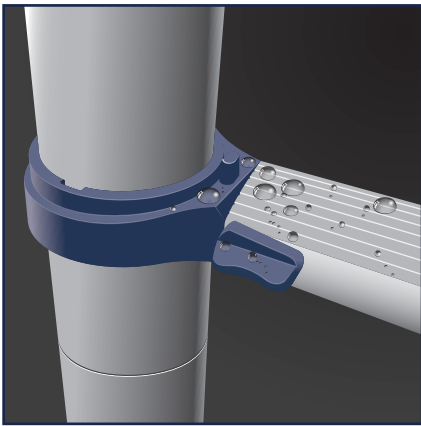

fig 18



MAINTENANCE TIPS



WIPE DOWN...

Wet Ladder

If the ladder is wet or if there is water on the ladder, open the ladder to the maximum and, with a dry cloth, absorb the water. It is recommended to let the ladder dry fully opened, on one side and then on the other, with the ladder leaning against a wall.

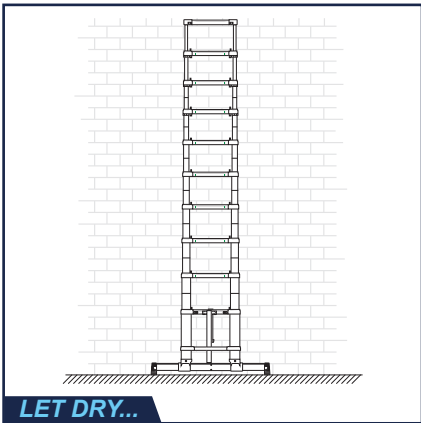

LET DRY...

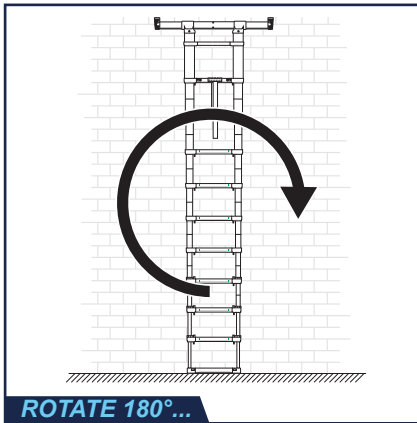

ROTATE 180°...

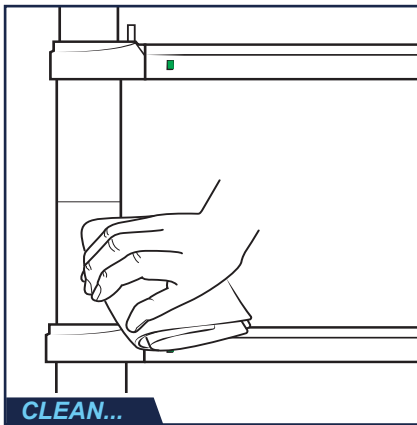
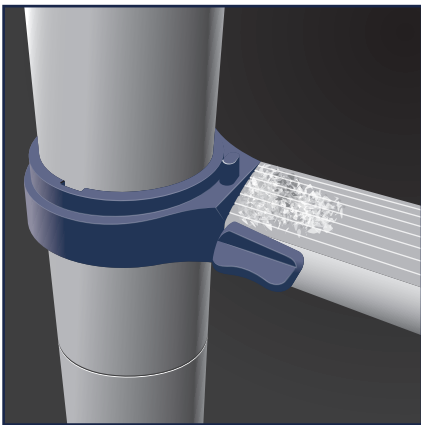

CLEAN...

Oxidised Ladder

If the ladder is oxidised (due to previous poor drying), there will be white residue on the stiles. First, remove the spots with a dry cloth. Then, to ensure the ladder deploys and retracts correctly, use a silicone based spray or a non-petroleum based furniture polish wipe once the ladder is fully opened and dry it correctly. Wait a few minutes and close the ladder. **NEVER** use a petroleum based product - it will damage the internal mechanism of your ladder.

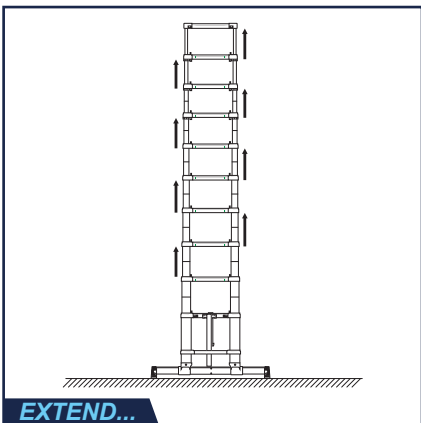

EXTEND...



MAINTAIN USING SILICONE...



NO OIL BASED LUBRICANTS...

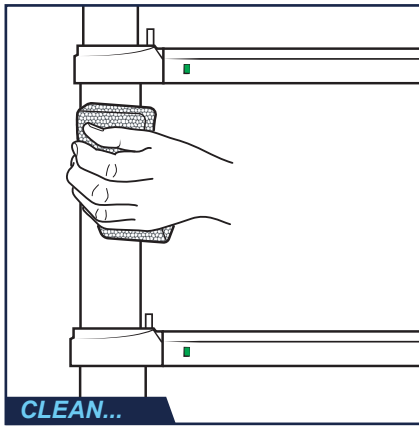
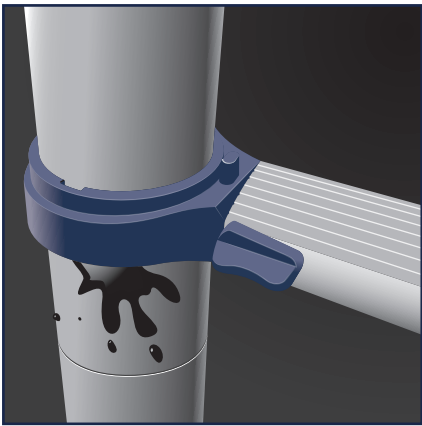

Paint or Other Substances Sticking to Stiles

If paint residues were left on the ladder, they must be removed using a sponge. Do not use steel wool since it might damage the opening/closing mechanism. After all residues have been removed from the stiles, apply a silicone based spray or a non-petroleum based furniture polish wipe as indicated in Oxidised Ladder section.

CLEAN...



MAINTAIN USING SILICONE...

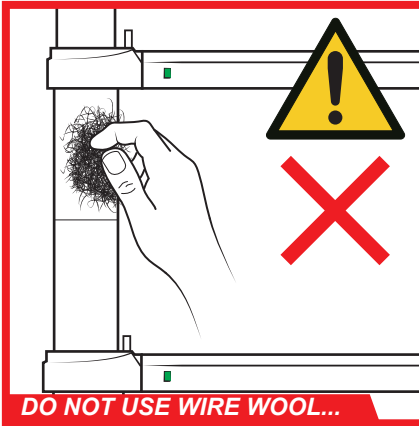

DO NOT USE WIRE WOOL...

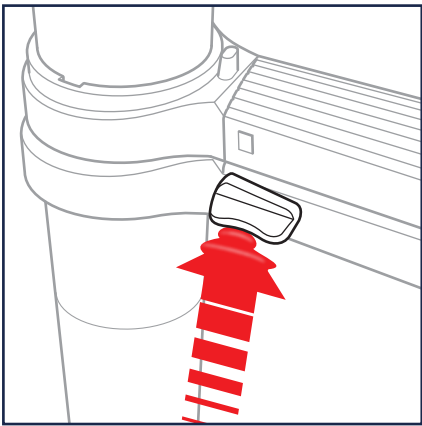

Hard to move Latches

If the latches are hard to push, use a compressor or compressed air duster to properly clean the latches. Then perform maintenance on the latches with a silicone based spray or a non-petroleum based furniture polish, wipe with a forward/backward movement. Dry excess spray with a dry cloth.

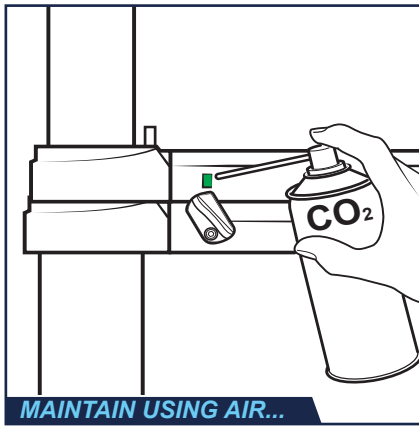

MAINTAIN USING AIR...

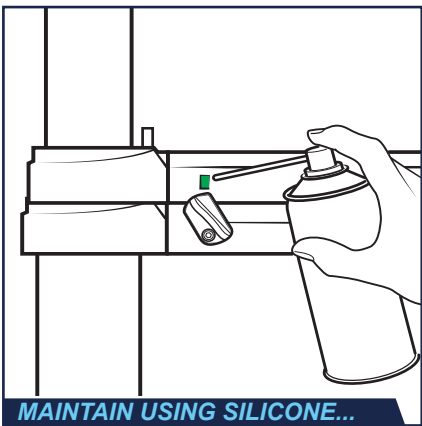

MAINTAIN USING SILICONE...

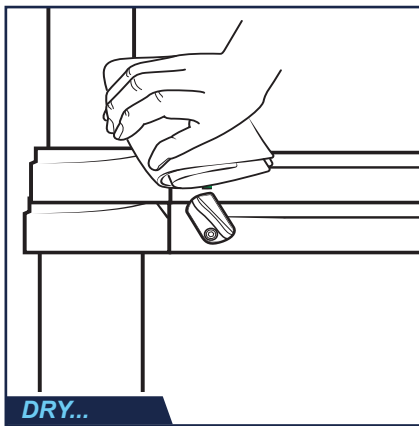

DRY...



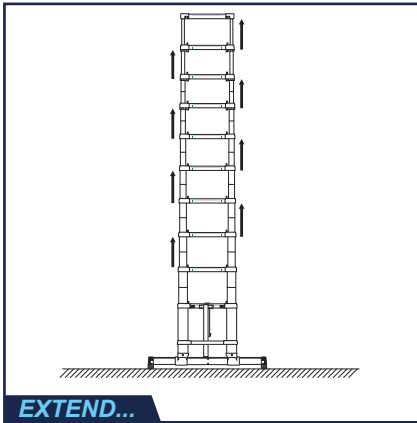
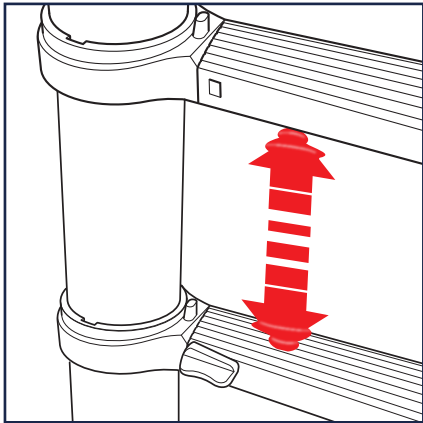

Difficulty in Opening or Closing the Ladder

If it becomes hard to open or close the ladder fully, extend the ladder, clean it, and maintain the stiles with a silicone based spray or a non-petroleum based furniture polish wipe. If the rungs are jammed, use the spray on every stile and close the ladder for 15 to 20 minutes to let the lubricant penetrate the ladder. Then, open and close the ladder to ensure the spray reaches every area of the ladder.

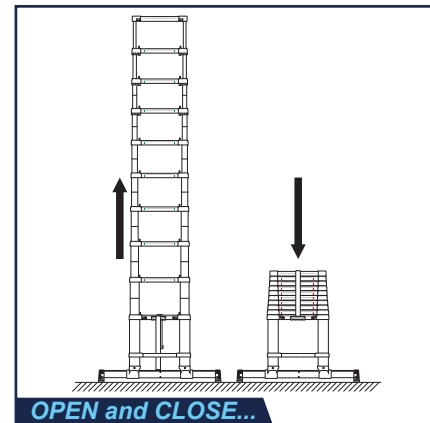
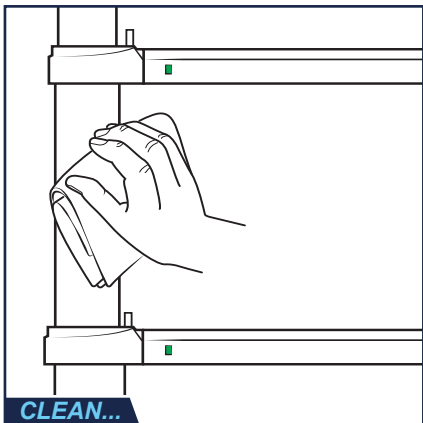

CLEAN...

MAINTAIN USING SILICONE...

OPEN and CLOSE...

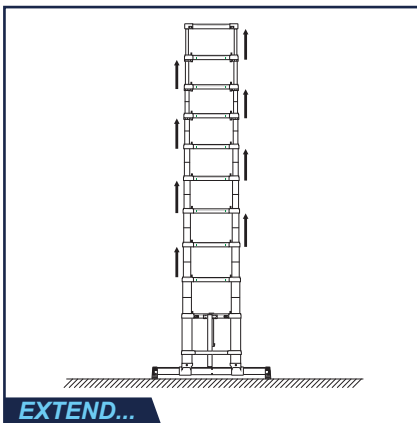

Winter Conditions

If the opening/closing of the ladder is affected by winter conditions, open the ladder in a dry area until the stiles reach room temperature i.e. 18-21°C. Ensure there is no humidity left on the stiles and couplings. (If there is humidity or oxidation, please refer to section **Wet Ladder** or **Oxidised Ladder**). Finally, with the ladder opened, lubricate all the stiles.

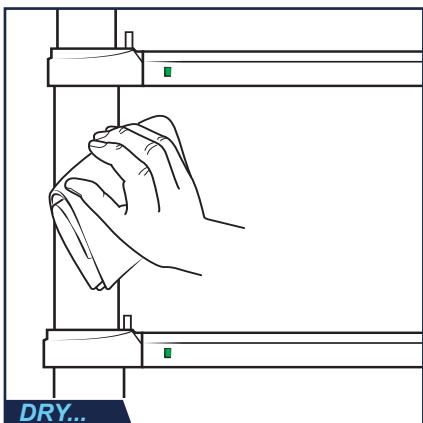

DRY...

MAINTAIN USING SILICONE...





WARNING: BEFORE USE, A THOROUGH INSPECTION OF THE LADDER MUST BE MADE. IF ANY OF THE CHECKS CANNOT BE FULLY SATISFIED, DO NOT USE THE LADDER.



Ladder Inspection

- ✓ Check that the stiles/legs (uprights) are not bent, bowed, twisted, dented, cracked or corroded.
- ✓ Check that the stiles/legs around the coupling, fixing point, are not dented cracked or corroded.
- ✓ Check that hardware (rivets, screws or bolts) are not missing, loose or corroded.
- ✓ Check that rungs/steps are not missing, loose, excessively worn, corroded or damaged.
- ✓ Check that the locking mechanisms are not missing, damaged, loose or corroded and that they engage properly on the mating stile.
- ✓ Check that the ladders feet are not missing, loose, excessively worn, corroded or damaged.
- ✓ Check that the entire ladder is free from contaminants (e.g. Dirt, mud, paint, oil or grease).
- ✓ Check that the locking mechanism for the stabiliser are not damaged or corroded and function and lock correctly.
- ✓ Check that the platform (if fitted) has no missing parts or fixings and is not damaged or corroded.

Repairs and Maintenance

- ✓ Shall be carried out by a competent person who has the skills to carry out repairs or maintenance, trained by the manufacturer or authorised distributor.
- ✓ For repair and replacement of parts, if necessary, contact the authorised distributor.
- ✓ Our customer service staff are available to help you with the product, to report damaged or missing parts, or for any other information about this product.

Keep Documents

- ✓ Retain user manual for future reference.
- ✓ Keep all the original sales invoice in a safe, dry place for proof of purchase.

LIMITED WARRANTY

XTEND+CLIMB® is a brand name of Core Distribution, Inc.

Core Distribution, Inc. has a Limited Lifetime Warranty. Core Distribution, Inc. will replace any Xtend+Climb® ladder should it fail due to defects in material or workmanship, under conditions and use to the original owner of the Xtend+Climb® ladder.

The Limited Lifetime Warranty is conditional upon the ladder being operated under normal conditions and use and properly maintained in accordance with the owner manual, as supplied with the ladder.

Xtend+Climb® ladders are tested to withstand normal wear and tear, but are not indestructible and can be damaged by misuse and neglect. Our warranty does not cover wear and tear, misuse and/or abusive treatment.

Additional Conditions: This Limited Lifetime Warranty is made solely to the original owner of this new Xtend+Climb® ladder and shall remain in force only as long as the original owner retains ownership of the ladder. This Limited Lifetime Warranty is not transferable.

In order to exercise your rights under this Limited Lifetime Warranty, the ladder must be presented to Xtend+Climb® or an authorised dealer, together with appropriate written proof of purchase, which identifies the ladders batch number.

Exclusions and Limitations

The warranty DOES NOT cover:

- Modifications from the original condition.
- Normal wear and tear.
- Use of the ladder for abnormal activities, or for purposes other than those for which the ladder was designed. Damage caused by failure to follow the instruction manual.
- Neglect and failure to care for the product.
- Surface finish and decal damage resulting from normal wear and tear.
- Labour and/or transport charges for full or part replacement. Repair, return or changeover. Accident, neglect, improper handling, abuse or wilful damage, misuse and improper use. Any alteration or repair by you or a third party who is not one of our authorised repairers.

This shall be in lieu of any other warranty, expressed or implied, including, but not limited to, any implied warranty of merchantability or suitable for a particular purpose. The liability of Core Distribution, Inc. under this warranty shall be limited solely to repair or replacement of the ladder within the warranty period; and Core Distribution, Inc. shall not be liable, under any circumstance, for consequential or incidental damages, including but not limited to, personal injury or labour costs.

The obligation to repair or replace this product at TB Davies, Ltd.'s option shall be company's only obligation with respect to defects in this product. This product must be returned, prepaid, together with sales slip or other proof of purchase.

Manufacturing specifications are subject to change without notice

Register your Warranty

<https://www.tbdavies.co.uk/warranty/tb-davies-warranty-registration/>

SPECIFICATIONS

SKU	Rungs x Sections	Last Climbing Height (m)	Approx. Working Height (m)	Closed Length (m)	Extended Length (m)	Width (m)	Stabiliser Bar Width (m)	Weight (kg)
1303-080	11 x 1	2.30	4.05	0.84	3.23	0.62	0.86	12.6
1303-081	13 x 1	2.90	4.65	0.90	3.83	0.62	0.88	15.5
1303-082	15 x 1	3.50	5.25	1.03	4.40	0.62	1.21	20.4
1303-086	10 x 1	2.00	3.75	0.78	2.90	0.47	N/A	9.1









Authorised Dealer

TB Davies (Cardiff) Ltd
Lewis Road,
Cardiff,
CF24 5EB,
Wales, UK
+44(0)2921320000
www.tbdavies.co.uk

